

# COBRA

THERMAL IMAGING BI-OCULAR

USER MANUAL

© 2019 AGM Global Vision. All rights reserved worldwide.

This documentation is subject to change without notice.

No parts of this manual, in whole or in part, may be copied, photocopied, translated, or transmitted by any electronic medium or in machine-readable form without the prior written permission of AGM Global Vision.

If you have questions that are not covered in this manual, or need service, contact AGM Global Vision customer support for additional information prior to returning a product.

## **AGM Global Vision**

**173 West Main Street**

**PO Box 962**

**Springerville, AZ 85938**

**Tel. 928.333.4300**

**Fax 480.393.4882**

**support@agmglobalvision.com**

**www.agmglobalvision.com**

## **EXPORT INFORMATION**

Buyer acknowledges that all products supplied by AGM Global Vision are subject to U.S. export control laws, including, but not limited to, the Export Administration Regulations, the International Economic Emergency Powers Act, and various U.S. embargoes and sanctions. AGM Global Vision products may not be exported, re-exported, or transferred contrary to U.S. export control laws. In particular, AGM Global Vision products may not be exported, re-exported, or transferred to prohibited countries, individuals, organizations, or entities, including but not limited to those individuals and entities listed on the List of Specially Designated Nationals and Blocked Persons administered or maintained by the U.S. Office of Foreign Assets Control ("OFAC"), the various lists maintained by the Bureau of Industry and Security of the Department of Commerce, and the U.S. State Department and Buyer represents and warrants that neither Buyer nor any of its officers, directors, or employees are on such lists. Distribution or resale by Buyer to such countries, individuals, organizations, or entities is expressly prohibited. Buyer has and will maintain a positive process to ensure compliance with this Section.

# LIST OF CONTENTS

TITLE	PAGE
Safety Summary	4
<b>1. GENERAL INFORMATION</b>	<b>5</b>
1.1 System Description	5
1.2 Standard Components	7
1.3 Optional Equipment	8
1.4 Key Features	9
<b>2. OPERATING INSTRUCTIONS</b>	<b>10</b>
2.1 Installation and Mounting	10
2.2 Controls and Display Indications	12
2.3 Operating Procedures	18
<b>3. MAINTENANCE AND TROUBLESHOOTING</b>	<b>21</b>
3.1 Operator Troubleshooting	21
3.2 Maintenance	22
<b>4. WARRANTY INFORMATION</b>	<b>24</b>
4.1 Warranty Information and Registration	24
<b>5. SPECIFICATIONS</b>	<b>26</b>
5.1 Specifications	26
<b>APPENDIX</b>	<b>28</b>
A. Spare Parts List	28

## SAFETY SUMMARY

- Read and follow all instructions
- Read all warnings
- Only use the attachments/accessories specified by the manufacturer
- All service must be provided by the manufacturer

### **WARNING:**

**This product contains natural rubber latex, which may cause allergic reactions!** The FDA has reported an increase in the number of deaths associated with sensitivity to natural latex proteins. If you are allergic to latex, learn which products contain it and strictly avoid exposure to those products.

### **CAUTION:**

- Do not dismantle the equipment.
- Keep the equipment clean. Protect it from moisture, dramatic temperature drops, and electrical shocks.
- DO NOT force the equipment controls past their stopping points.
- DO NOT leave the equipment activated during breaks in operation.
- DO NOT store the equipment with the batteries installed.
- Thoroughly clean and dry each item before placing them into the storage case.

### **CAUTION:**

To prevent thermal damage to the equipment, never point it, either on or off, directly at the sun or any other source of high intensity light that the unprotected human eye cannot tolerate (such as a welding arc). To prevent inadvertent exposure to these types of sources, never leave the equipment with the objective lens cap off.

### **NOTES:**

- To avoid losing unsaved data, DO NOT remove the batteries or disconnect the external power source while the Cobra is on.
- Inadvertent sun damage is not considered a defect in material or workmanship, and is therefore not covered in the product warranty.

# 1 GENERAL INFORMATION

## 1.1 SYSTEM DESCRIPTION

The Cobra consists of next primary parts: a body, a lens assembly and an eyepiece assembly. Figure 1-1 represents two versions of the equipment: one including a 50 mm focal length objective lens, and the other with a 75 mm focal length objective lens.

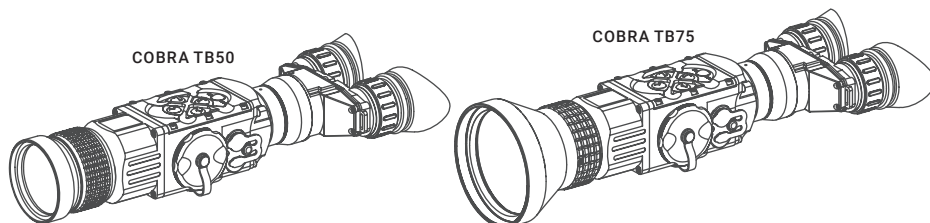

FIGURE 1-1. COBRA THERMAL IMAGING BI-OCULAR

The Cobra is a thermosensitive device. It senses the differences in heat emitted by objects in its field of view, and converts the received temperature pattern into a viewable image that represents the scene in contrasting black & white or color patterns, depending on the user's selected image palette.

### **NOTE:**

It is important that the Cobra sensor receive sufficient thermal contrast between the target and background area, or between the different parts of a target. For example, there would be a vast temperature contrast between the snow and any heat target (such as an animal), making it exceptionally easy to distinguish the target.

The main optical-electronic components of the Cobra include: an objective Germanium thermal lens, two eyepieces, a thermal-imaging camera, a display, a control card, and a button control panel.

The Cobra is equipped with manual eyepiece and objective lens focusing.

To accommodate individual user needs, the Cobra has a variety of digitally controlled options such as:

- Display Brightness
- Digital Zoom
- Palette Color Selection
- User-Controlled Manual Non-Uniformity Correction/ Flat-Field Correction (UCMNUC/ FFC)
- Imaging Enhancements
- Custom Settings

All Cobra devices are based on FLIR Tau 2 cameras that allow for improvements in overall image quality in a wide range of dynamic thermal environments. The Cobra has employed special user-adjustable imaging tools that include:

- **Active Contrast Enhancement (ACE)** – a digital “Contrast” correction that allows for smart scene optimization based on dynamic adjustments, where a variety of contrast levels occur depending on relative scene temperature.
- **Second Generation Digital Detail Enhancement (DDE)** – a “Sharpness” correction that digitally enhances the picture, significantly sharpens edges, and further reduces image noise.
- **Smart Scene Optimization (SSO)** – a fine-tuning computational correction that significantly improves overall visual acuity for targets that have thermal signatures similar to the surrounding background.
- **Information-Based Histogram Equalization (IBHEQ)** – a “Sky/Sea” enhancement – information-based environment dependent algorithm that automatically adjusts camera gain and excludes pixels determined to not contain critical information. Specifically helpful in scenes with great expanses of visible sky or water.
- **User-Controlled Manual Non-Uniformity Correction/ Flat-Field Correction (UCMNUC/ FFC).** There is a mechanical shutter between the camera sensor and the lens. This shutter is used to perform a non-uniformity correction (NUC), also known as flat-field correction (FFC). During FFC, the shutter presents a uniform temperature source to each detector element in the array. While imaging the flat-field source, the camera updates the offset correction coefficients, resulting in a more uniform image after the process is complete. All Cobra models allow for user to manually trigger or interrupt scheduled UCMNUC/ FFC function.
- **Silent Shutterless NUC™ (SSN)** – In addition to User-Controlled Manual NUC/ FFC, all Cobra models employ a digital, supplemental, non-mechanical flat-field correction that extends periods between mechanical shutter events and further reduces image noise. SSN is an always ON enhancement.

Information on the current operating state (battery status, active function in the display etc.) is continuously displayed, making field operation of the Cobra simple and convenient.

Manufactured for exceptional durability, the Cobra has a lightweight and robust aluminum body. A side Picatinny/ Weaver rail allows for the installation of an optional HD Video Recorder, WiFi Attachment, Extended Battery Pack, or other equipment.

A standard NTSC/PAL video input/ output connector enables an external video display (monitor/ TV) or video recorder to be connected to the Cobra.

The Cobra is powered by two CR123A (2×3V) batteries. An external 6VDC/600mA power source and USB power bank can also be connected to the Cobra.

Figure 1-2 shows the Cobra. The ITEM NO. column of Table 1-1 indicates the number used to identify items in Figure 1-2.

**NOTE:**

Here and below, the example used is the Cobra with a 50mm lens.

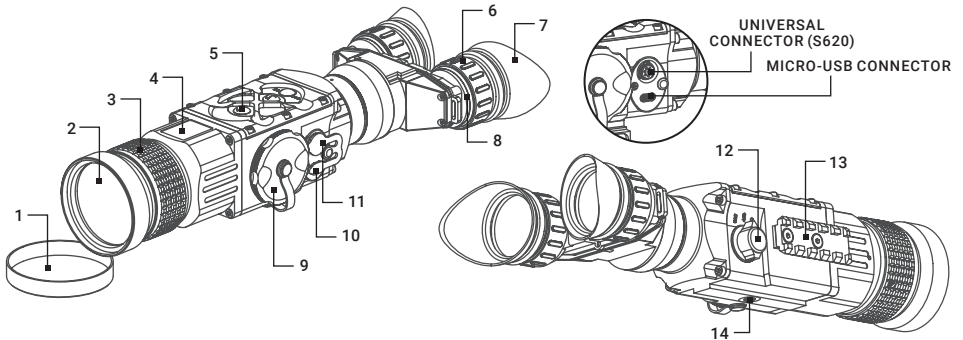

FIGURE 1-2. COBRA THERMAL IMAGING BI-OCULAR. SYSTEM DESCRIPTION

TABLE 1-1. SYSTEM DESCRIPTION

ITEM	DESCRIPTION
1	Objective Lens Cap
2	Objective Lens
3	Objective Focus Ring
4	Body
5	Button Control Panel
6	Eyepiece Focus Ring
7	Eyecup

ITEM	DESCRIPTION
8	Eyepiece
9	Battery Cap
10	Mini USB Connector with a Cap
11	Universal Connector with a Cap
12	Operation Switch
13	Side Picatinny/Weaver Rail
14	Tripod Socket

## 1.2 STANDARD COMPONENTS

The Cobra standard components are shown in Figure 1-3 and listed in Table 1-2.

The ITEM column indicates the number used to identify items in Figure 1-3.

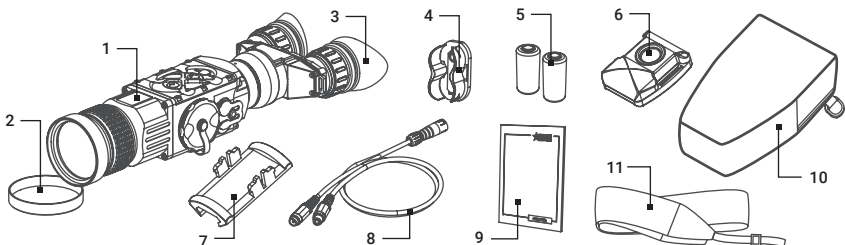

FIGURE 1-3. STANDARD COMPONENTS

**TABLE 1-2. STANDARD COMPONENTS**

ITEM	DESCRIPTION	QUANTITY
1	Cobra Thermal Imaging Bi-Ocular	1
2	Objective Lens Cap	1
3	Eyecup	2
4	Battery Cassette	2
5	CR123A Lithium Battery	2
6	Wireless Remote Control	1
7	Picatinny Adapter for Wireless Remote Control	1
8	Video Cable	1
9	Operation and Maintenance Manual	1
10	Carrying Case	1
11	Neck Strap	1

### 1.3 OPTIONAL EQUIPMENT

Optional items are shown in Figure 1-4 and listed in Table 1-3.

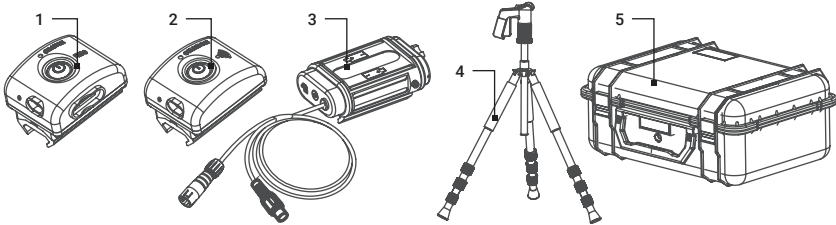

**FIGURE 1-4. OPTIONAL EQUIPMENT**

The ITEM column indicates the number used to identify items in Figure 1-4.

The PART NO. column indicates the primary number used by the manufacturer, to identify an item.

**TABLE 1-3. OPTIONAL EQUIPMENT**

ITEM	DESCRIPTION	PART NO.
1	AGM WiFi Attachment	6305WIF1
2	AGM HD Recorder	6305HDR1
3	AGM Extended Battery Pack	6308EXB1
4	Professional Titanium Tripod with a Grip	6606TTR1
5	Hard Case for Storage/Transportation	6610HCS1



## 1.4 KEY FEATURES

- High-performance thermal imaging camera
- Lightweight and robust design
- Easy to operate
- Manually adjustable eyepiece and objective lens
- Real-time display
- Digitally controlled features:
  - Palette
  - Enhancement
  - Settings
  - Display Brightness
  - Electronic Magnification
  - User-Controlled Manual Non-Uniformity Correction / Flat-Field Correction (UCMNUC/FFC)
- Current operational state information display (battery status, active profile, palette setting)
- Wireless remote control
- Analog video input and output
- Powered by two standard CR123A batteries
- Power input capability
- Digital HD video recorder (optional)
- External Wi-Fi module (optional)
- Serviceability under severe conditions
- Filled with dry nitrogen to prevent internal fogging
- Waterproof
- Tripod mountable
- Limited 3-year warranty

## 2 OPERATING INSTRUCTIONS

### 2.1 INSTALLATION AND MOUNTING

#### 2.1.1 BATTERY INSTALLATION

**CAUTION:**

Verify that the equipment is OFF before installing the batteries.

To install two CR123A batteries (refer to Figure 2-1):

1. Unscrew the battery cap (A).
2. Remove the battery cassette (B).
3. Insert the batteries (C) into the cassette. Align the polarity symbols on the batteries with the polarity symbols on the cassette.
4. Insert the cassette with installed batteries.
5. Replace the battery cap.

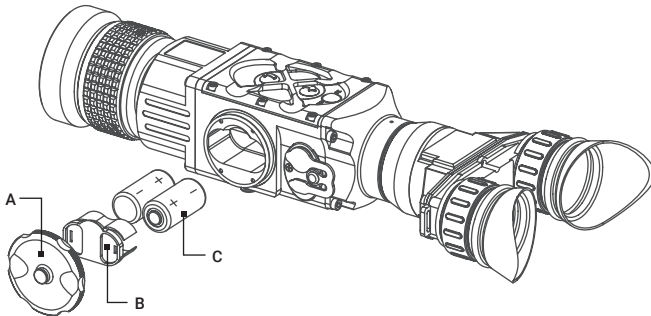

FIGURE 2-1. BATTERY INSTALLATION

#### 2.1.2 FASTENING AN ADVANCED WIRELESS REMOTE CONTROL

Using the supplied Velcro® tape (A, Figure 2-2), fasten the remote control (B) to an easily accessible place.

You can use the Picatinny adapter for the wireless remote control (C) for mounting the remote control to Picatinny or Weaver rail. Install the adapter onto the rail (D). Insert the remote control into the adapter.

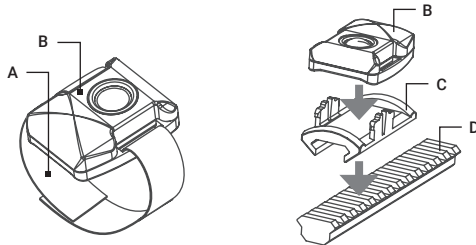

FIGURE 2-2. WIRELESS REMOTE CONTROL

### 2.1.3 INSTALLING ADDITIONAL EQUIPMENT

Use the side Picatinny/Weaver rail to install any additional equipment, such as the AGM HD Video Recorder, WiFi Attachment, or the Extended Battery Pack.

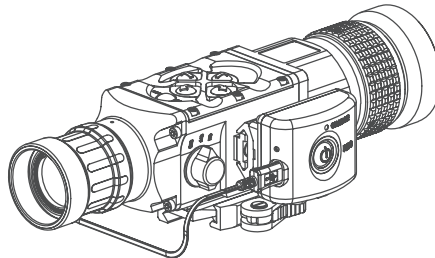

FIGURE 2-11. HD RECORDER INSTALLATION

### 2.1.4 CONNECTING AN ADDITIONAL EQUIPMENT

**CAUTION:**

Turn off the Cobra before you begin connecting/disconnecting any external equipment and before removing the batteries.

Remove the connector protective cap (see Figure 1-2).

Connect a cable of the external 5V battery bank to the Cobra Micro-USB connector.

Connect a cable of Digital Video Recorder, WiFi Attachment, or the Extended Battery Pack to the Cobra S620 universal connector.

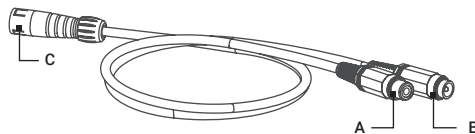

FIGURE 2-4. VIDEO CABLE

Use the video cable plug (A, Figure 2-12) to connect an external video recorder/monitor/TV to the Cobra. Connect the video cable plug (C) to the Cobra S620 universal connector.

Use the video cable plug (B) to connect an external power source (6 VDC / 600 mA) to the Asp. Connect the video cable plug (C) to the Cobra S620 universal connector.

**NOTE:**

The external power supply must have a standard OD double-pole socket with a positive central contact.

**CAUTION:**

After removing the cable, replace the protective cap over the connector.

### 2.1.5 INSTALLING THE COBRA ON A TRIPOD

To mount the Cobra to a tripod, screw the tripod into the 1/4" threaded socket located on the bottom of the Cobra.

**CAUTION:**

The unit may be badly damaged if the tripod collapses or falls over. Remove the unit from the tripod if it is not within your reach.

## 2.2 CONTROLS AND DISPLAY INDICATIONS

### 2.2.1 CONTROLS

**CAUTION:**

DO NOT force the equipment controls past their stopping points.

The Cobra controls are shown in Figures 2-5 and 2-6, and are defined in Tables 2-1 and 2-2. The ITEM columns indicate the numbers used to identify items in the figures.

**NOTE:**

Various display symbols indicating the current operating state of the Cobra can be displayed permanently, may appear momentarily, or can be set to appear only when a certain function is activated.

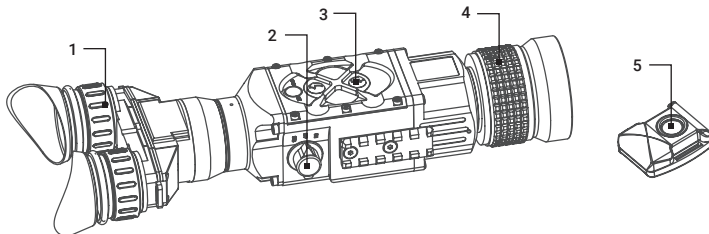

FIGURE 2-5. CONTROLS

**TABLE 2-1. CONTROLS AND INDICATORS**

ITEM	CONTROL/INDICATOR	FUNCTION
1	Eyepiece Focus Ring	Adjusts the eyepiece diopter. The total diopter adjustment range is covered with 2 turns of the ring.
2	Operation Switch	Activates the Cobra when turned to ON.
		Activates Standby mode when turned to STB.
		Deactivates the Cobra when turned to OFF.
3	Control Panel Buttons	Configures operational settings. See Table 3-2 for button functions.
4	Objective Focus Ring	Focuses the objective lens. Adjusts for sharpest view of the scene. The total focus range is covered with three quarter turns of the lens.
5	Remote Control Button	Activates/ deactivates the Cobra in standby mode. To turn the unit on, press the button once. Press it again to turn the unit off.
—	Battery Status Indicator	The color fill (green/ yellow/ red) bar in the battery icon indicates the current power level of the internal battery, or remaining battery life.
		The totally shaded battery icon indicates the fully charged battery.
		The flashing transparent battery icon indicates a low battery.

The Cobra button control panel is shown in Figure 2-6.

Table 2-2 contains the button functions and their descriptions. The ITEM column indicates the number used to identify buttons in Figure 2-6.

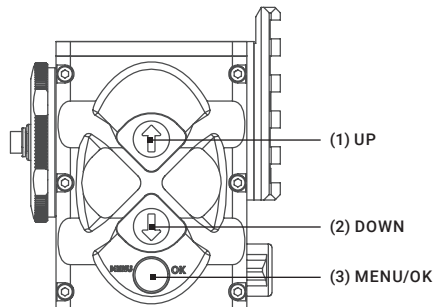

**FIGURE 2-6. BUTTON CONTROL PANEL**

**NOTE:**

Each button is responsible for different functions, selected by pushing or holding down the button, or using the button in combination with a second one (as described in Table 2-2). Pushing a button for 1.5+ seconds is considered “holding down.”

**TABLE 2-2. BUTTON CONTROLS**

ITEM	FUNCTION	DESCRIPTION
1	Display Brightness increase	Push button (1) to increase the screen brightness.
	Digital Zoom Control	To change the zoom gradually, push and hold button (1).
	Up	Use the UP (1) button to navigate through the items on the menu.
2	Display Brightness Decrease	Push button (2) to decrease the screen brightness.
	Image Palette Control	To scroll through the available palettes, hold down button (2). There are 13 palettes available: White Hot, Black Hot, Fusion, Rainbow, Globow, Ironbow 1, Ironbow 2, Sepia, Color 1, Color 2, Ice-Fire, Rain, and OEM.
	Down	Use the DOWN (2) button to navigate through items on the menu.
1 + 2	Flat Field orrection (FFC)	Simultaneously holding down buttons (1) and (2) induces manual Flat Field Correction (FFC).
3	MENU	Holding down button (3) will bring up the Main Menu. The menu includes the following functions: Palette, Enhancement, and Settings.
	OK	Push the OK button (3) to view the settings available for the item selected. To enable left and right navigation (< >) press button (3).
	FFC Process Interruption	Pushing button (3) when the countdown is on the screen will cancel the FFC, and the shutter will not interrupt viewing.

### 2.2.2 MAIN MENU

Most setup options can be accessed from the MAIN MENU.

To display the MAIN MENU, hold down button (3) on the control panel (Figure 2-6).

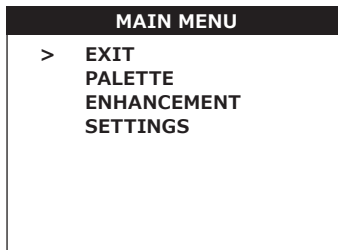

**FIGURE 2-7. MAIN MENU**

Once the MAIN MENU is displayed (Figure 2-7), use buttons (1) and (2) to navigate through items on the menu.

Push button (3) to view the settings available for the item selected.

Navigate through sub-menu items by pushing buttons (1) and (2), except where otherwise indicated.

After a menu item is selected, push button (3) to activate the selected function. The function will either be activated or will show <> symbols.

When <> symbols are shown on the menu, the left and the right actions are required. Use button (1) to increase (>) the value, and button (2) to decrease (<) the value. To enter the value and disable left and right navigation, press button (3).

Select EXIT and push button (3) to return to the MAIN MENU.

### Palette Menu

The PALETTE menu (Figure 2-8 and Figure 2-9) allows you to select from a range of temperature imaging modes: White Hot, Black Hot, Fusion, Rainbow, Globow, Ironbow 1, Ironbow 2, Sepia, Color 1, Color 2, Ice-Fire, Rain, and OEM Custom.

#### NOTE:

To navigate through the items on the two-page PALETTE menu, hold down button (1) or button (2).

The palettes act as color templates for visualization of temperature changes.

To navigate through the items on the PALETTE menu, press buttons (1) or (2).

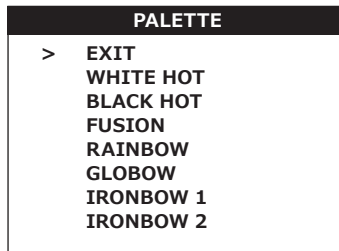

FIGURE 2-8. PALETTE MENU

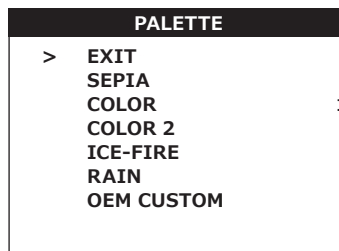

FIGURE 2-9. PALETTE MENU. CONTINUED

**NOTE:**

The most popular palettes are White Hot and Black Hot, usually known as inversion. White Hot mode is ideal for spotting targets, while Black Hot is most useful for situational reading.

**NOTE:**

Training and experience are required to quickly and properly interpret thermal images.

**Enhancement Menu**

The ENHANCEMENT menu (Figure 2-10) allows users to take advantage of advanced signal processing algorithms to improve image quality under a variety of different thermal environments.

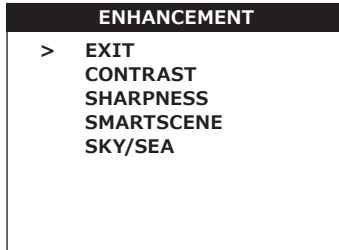

FIGURE 2-10. ENHANCEMENT MENU

CONTRAST - Active Contrast Enhancement (ACE) – a digital contrast correction that allows for a smart scene optimization based on dynamic adjustments where a variety of contrast levels occur depending on relative scene temperature. The adjustment range is from -8 to +8 with default value 4. Lower values will make hotter objects get more contrast and higher values will make a colder objects get more contrast.

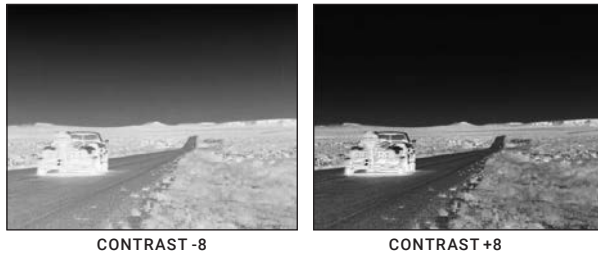
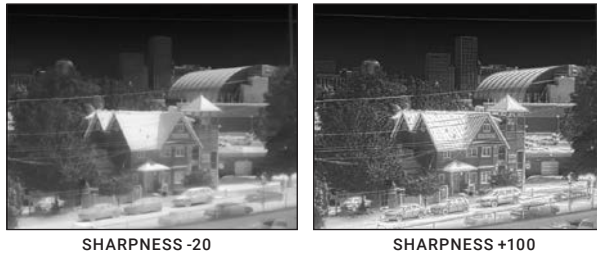

FIGURE 2-11. DIGITAL CONTRAST CORRECTION

SHARPNESS - Second Generation Digital Detail Enhancement (DDE) – a sharpness correction that is digitally enhances the picture to present clearer imagery, significantly improves edge sharpening and further reduces image noise. The adjustment range is from -20 to +100 with default value 60. Lower values will create an object image with softer edges. Higher values will make an object sharper, enhance details and will further increase the signal to noise ratio.





**FIGURE 2-12. SHARPNESS CORRECTION**

**SMART SCENE - Smart Scene Optimization (SSO)** – a fine-tuning computational correction that significantly improves an overall visual acuity for targets that have thermal signatures similar to a surrounding background. Higher values provide a more linear automatic gain control behavior and objects with similar, but not the same temperature can be differentiated with greater accuracy. The adjustment range is from 0 to 100 with default value 15.

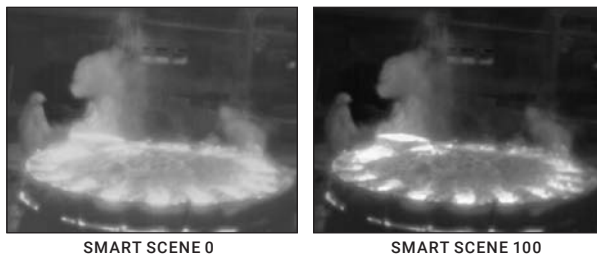

**FIGURE 2-13. SMART SCENE OPTIMIZATION**

**GAIN - Automatic Gain Control (AGC)** – a correction that used to automatically adjust the gain to an appropriate range, the weaker the image signal, the stronger the gain. The adjustment range is from 0 to 255 with default value 35.



**FIGURE 2-14. GAIN CORRECTION**

**AGC SPEED** – parameter that allows user to control the refresh rate of Automatic Gain Control (AGC). The adjustment range is from 0 to 128 with a default value of 12.

## Settings Menu

The SETTINGS menu (Figure 2-15) allows for direct changes to Video Standards and Factory Default settings.

The Firmware (FW) revision number is listed at the bottom of the menu display.

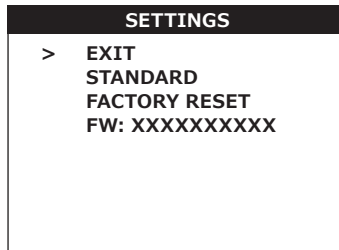

FIGURE 2-15. SETTINGS MENU

### STANDARD

Changes the video output standard between NTSC and PAL.

### FACTORY RESET

Resets the camera to factory defaults.

### SOFTWARE VERSION

Software release is shown in alphanumeric format. When the SELECT button is pushed, the SW version will appear.

### NOTE:

After configuration is complete, select EXIT on the MAIN MENU and push button (3). All settings will be saved.

## 2.3 OPERATING PROCEDURES

### 2.3.1 OPERATING

#### CAUTION:

DO NOT force the equipment controls past their stopping points.

#### CAUTION:

To prevent thermal damage to the equipment, never point it, either powered or not, directly at the sun or any other source of high intensity light that the unprotected human eye cannot tolerate (such as a welding arc). To prevent inadvertent exposure to these sources, never leave the equipment without the objective lens cap secured.

Operating procedures are as follows:

1. Remove the Cobra from the carrying case.
2. Remove the objective lens cap.
3. Point the equipment at an object.

4. Activate the Cobra by turning the operation switch ON. After approximately 3 sec, video of the thermal scene should appear.
5. Adjust the Cobra for your eyesight by turning the eyepiece focus rings CW up to the stop, and then CCW until the display and symbols are as clear as possible. Bring the object into focus by turning the objective focus ring (CW for far focus, CCW for near focus).

**NOTE:**

The total diopter adjustment range is covered with 2 turns of the eyepiece focus ring.  
The total focus range is covered with three quarter turns of the objective focus ring.

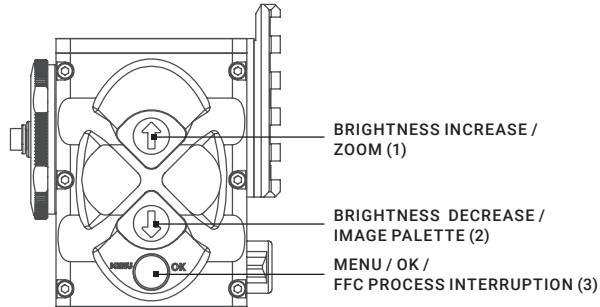

**FIGURE 2-16. SETTING BUTTONS**

6. Using the buttons on the control panel (Figure 2-16), configure the Cobra to adapt it to your situation.

For more information on operational setting procedures, see Part 2.2 (Controls and Display Indications).

- A. Adjust the brightness of the display for your comfort.

Push buttons (1) and (2) to increase/ decrease the display brightness by one level at a time until you reach your desired brightness level.

- B. Use FFC (Flat Field Correction) to improve image quality.

Push buttons (1) and (2) simultaneously to start manual Flat Field Correction.

If necessary, interrupt the automatic process by pushing the OK button (3) on the control panel during the 5-second countdown, which will appear at the bottom of the display.

- C. Use the digital zoom to magnify the central area of the image.

Hold down button (1) to slowly zoom in on the image. The 2x, 4x, and 8x symbols (maximum zoom factor is dependent on equipment model) will appear on the display.

**NOTE:**

Digital zoom allows distant objects to appear larger; however, the resolution will be compromised.

- D. Use the image palettes for optimal visualization of temperature changes in the scene.

Hold down the palette control button (2) to scroll through available palettes. The palette name will appear in the top part of the display.

- E. Adjust the necessary adjustment using the MAIN MENU. See Part 2.2.2 (Using the MAIN MENU).

**NOTE:**

After configuration is complete, select EXIT on the MAIN MENU and push the OK button to leave the MAIN MENU. All settings will be saved.

7. To operate the Cobra with wireless remote control, turn the operation switch to the STB position (Standby). After it the remote control button can activate/ deactivate the device in two ways:
- 1) To turn the device on, press the remote control button once, to turn it off – press the button again.
  - 2) To operate the device in short-time activation mode (see note below), press and hold the remote control button down for 1.5+ seconds. Release the remote control button to deactivate the device.

**CAUTION:**

**DO NOT** leave the equipment activated when not in use.

### **2.3.2 COBRA SHUT-DOWN**

**NOTE:**

Shut down the Cobra properly to avoid losing unsaved settings and data.

Shut-down the Cobra as follows:

1. Be sure to save your settings and data.
2. Turn off the Cobra.
3. Place the protective cap on the objective lens.
4. Disconnect the cable (if applicable).
5. Place the protective cap on the connector.
6. Remove the batteries.

**CAUTION:**

**Do not store the Cobra with the batteries still installed.**

7. Store the Cobra and all accessories in the carrying case.

# 3 MAINTENANCE INSTRUCTIONS

## 3.1 OPERATOR TROUBLESHOOTING

The purpose of troubleshooting is to identify the most frequent equipment malfunctions, probable causes, and corrective actions required.

Table 3-1 lists the common malfunctions that may be found during the operation or maintenance of the Cobra. Perform the tests/ inspections and corrective actions in the order listed.

This table does not list all of the malfunctions that may occur with your device, or all of the tests and corrective actions that may be necessary. If you experience an equipment malfunction that is not listed, or is not fixed by the corrective actions listed in the table, please contact Customer Service centre.

**TABLE 3-1. OPERATOR TROUBLESHOOTING**

MALFUNCTION	PROBABLE CAUSE/ TEST/ INSPECTION	CORRECTIVE ACTION
The Cobra fails to activate.	Batteries are missing or improperly installed.	Insert batteries or install correctly.
	Batteries are dead.	Replace the batteries.
	Batteries, surfaces, or contacts are dirty or corroded.	Clean the contact surfaces with a pencil eraser and/or alcohol and cotton swabs.
	Remote control unit is damaged.	Please contact Customer Support.
	Remote control battery is dead.	Replace the battery as per Part 3.2.3.
	The equipment is damaged.	Please contact Customer Support.
The Cobra is not responsive to control buttons.	The equipment is damaged.	Please contact Customer Support.
Remote control does not work.	Battery is missing or improperly installed.	Insert battery or install correctly.
	Battery is dead.	Replace the battery.
	Battery surfaces or contacts are dirty or corroded.	Clean the contact surfaces with a pencil eraser and/or alcohol and cotton swabs.
	Remote control unit is damaged.	Please contact Customer Support.

MALFUNCTION	PROBABLE CAUSE/ TEST/ INSPECTION	CORRECTIVE ACTION
Poor image quality.	Check objective lens and eyepieces focus.	Refocus.
	Check for fogging or dirt on objective lens and eyepieces.	Clean the lenses as detailed in Part 2.2.2.
	The equipment is damaged.	Please contact Customer Support.
No image on an external monitor.	Video cable is damaged.	Replace the video cable with a new one. If this is not effective, please contact Customer Support.
	The equipment is damaged.	Please contact Customer Support.
Hindered rotation of the battery cap.	Dirty cap thread.	Clean the thread.
	Damaged cap thread.	Replace the cap with a new one. If this is not effective, please contact Customer Support.
Light is visible around eyecups.	Check eyecups resilience.	If the eyecups are defective, please contact Customer Support.

## 3.2 MAINTENANCE

### 3.2.1 GENERAL

The Cobra operator maintenance consists of operational tests, inspections for unit serviceability, cleaning and mounting procedures, and corrective actions (troubleshooting and replacement of a limited number of parts). Maintenance instructions covered elsewhere in this manual (troubleshooting, etc.) are not repeated in this section.

#### **CAUTION:**

The Cobra is a precision electro-optical instrument and must be handled carefully at all times to prevent damage.

#### **CAUTION:**

**DO NOT** dismantle the equipment.

### 3.2.2 CLEANING PROCEDURES

Clean the Cobra and optional items as follows:

1. Gently brush off any dirt from the equipment using only a clean, soft cloth.
2. Moisten the cloth with fresh water and gently wipe the external surfaces (except for optical surfaces).
3. Dry any wet surfaces (except for optical surfaces) with another clean, dry, soft cloth.
4. Using a lens brush, carefully remove all loose dirt from optical surfaces (objective lens and eyepiece).

5. Dampen a cotton swab with ethanol and lightly and slowly wipe optical surface. Clean the optical surface using circular movements, starting from the centre and moving out towards the edge, not touching the lens holder and changing the cotton swab after each circular stroke. Repeat until the optical surface is clean.
6. Clean the battery contact surfaces and contact springs with a pencil eraser and/or alcohol and cotton swabs.

**CAUTION:**

Thoroughly dry each item before replacing into the storage/ carrying case.

### 3.2.3 BATTERY REMOVAL AND REPLACEMENT

Refer to Part 2.1.1 for battery installation procedures.

Replace the remote control battery as follows:

1. Using a screwdriver, unscrew the four screws (A, Figure 3-1) that secure the cover to the bottom of the unit. Remove the cover.

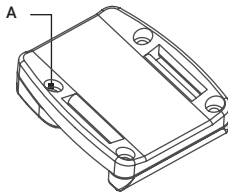

FIGURE 3-1. WIRELESS REMOTE CONTROL BATTERY INSTALLATION

2. Replace the battery with new one (CR2032, 3V). Install the battery, aligning their polarity markings (+/-) with those embossed on the compartment.
3. Replace the cover and tighten the screws (A).

# 4 WARRANTY INFORMATION

## 4.1 WARRANTY INFORMATION AND REGISTRATION

### 4.1.1 WARRANTY INFORMATION

This product is guaranteed to be free from manufacturing defects in material and workmanship under normal use for a period of three (3) years from the date of purchase. In the event that a defect covered by the warranty below occurs during the applicable period stated above, AGM Global Vision, at its discretion, will either repair or replace the product; such action on the part of AGM Global Vision shall be the full extent of AGM Global Vision's liability, and the Customer's sole and exclusive repairation. This warranty does not cover a product if it has been (a) used in ways other than its normal and customary manner; (b) subjected to misuse; (c) subjected to alterations, modifications or repairs by the Customer or by any party other than AGM Global Vision without prior written consent of AGM Global Vision; (d) is the result of a special order or categorized as "close-out" merchandise or merchandise sold "as-is" by either AGM Global Vision or the AGM Global Vision dealer; or (e) merchandise that has been discontinued by the manufacturer and either parts or replacement units are not available due to reasons beyond the control of AGM Global Vision. AGM Global Vision shall not be responsible for any defects or damage that in AGM Global Vision's view are a result from the mishandling, abuse, misuse, improper storage or improper operation of the device, including use in conjunction with equipment that is electrically or mechanically incompatible with, or of inferior quality to, the product, as well as failure to maintain the environmental conditions specified by the manufacturer. This warranty is extended only to the original purchaser. Any breach of this warranty shall be enforced unless the customer notifies AGM Global Vision at the address noted below within the applicable warranty period.

The customer understands and agrees that except for the foregoing warranty, no other warranties written or oral, statutory, expressed or implied, including any implied warranty of merchantability or fitness for a particular purpose, shall apply to the product. All such implied warranties are hereby and expressly disclaimed.

### 4.1.2 LIMITATION OF LIABILITY

AGM Global Vision will not be liable for any claims, actions, suits, proceedings, costs, expenses, damages, or liabilities arising out of the use of this product. Operation and use of the product are the sole responsibility of the Customer. AGM Global Vision's sole undertaking is limited to providing the products and services outlined herein in accordance with the terms and conditions of this Agreement. The provision of products sold and services performed by AGM Global Vision to the Customer shall not be interpreted, construed, or regarded, either expressly or implied, as being for the benefit of or creating any obligation toward any third party of legal entity outside AGM Global Vision and the Customer; AGM Global Vision's obligations under this Agreement extend solely to the Customer. AGM Global Vision's liability hereunder for damages, regardless of the form or action, shall not exceed the fees or other charges paid to AGM Global Vision by the customer or customer's dealer. AGM Global Vision shall not, in any event, be liable for special, indirect, incidental, or consequential damages, including, but not limited to, lost income, lost revenue, or lost profit, whether such damages were foreseeable or not at the time of purchase, and whether or not such damages arise out of a breach of warranty, a breach of agreement, negligence, strict liability, or any other theory of liability.



### **4.1.3 PRODUCT REGISTRATION**

In order to validate the warranty on your product, the customer must complete and submit AGM Global Vision PRODUCT REGISTRATION FORM on our website ([www.agmglobalvision.com/customer-support](http://www.agmglobalvision.com/customer-support)).

### **4.1.4 OBTAINING WARRANTY SERVICE**

To obtain warranty service on your unit, the End-user (Customer) must notify the AGM Global Vision service department via e-mail. Send any requests to [support@agmglobalvision.com](mailto:support@agmglobalvision.com) to receive a Return Merchandise Authorization number (RMA). When returning any device, please take the product to your retailer, or send the product, postage paid and with a copy of your sales receipt, to AGM Global Vision's service centre at the address listed above. All merchandise must be fully insured with the correct postage; AGM Global Vision will not be responsible for improper postage or merchandise that becomes lost or damaged during shipment. When sending product back, please clearly write the RMA# on the outside of the shipping box. Please include a letter that indicates your RMA#, the Customer's Name, a Return Address, reason for the return, contact information (valid telephone numbers and/or an e-mail address), and proof of purchase that will help us to establish the valid start date of the warranty. Product merchandise returns that do not have an RMA# listed may be refused, or a significant delay in processing may occur. Estimated Warranty service time is 10-20 business days. The End-user/Customer is responsible for postage to AGM Global Vision for warranty service. AGM Global Vision will cover return postage/shipping after warranty repair to the End-user/Customer only if the product is covered by the aforementioned warranty. AGM Global Vision will return the product after warranty service by domestic UPS Ground service and/or domestic mail. Should any other requested, required, or international shipping methods be necessary, the postage/shipping fee will be the responsibility of the End-user/Customer.

For service, repair or replacement, please contact:

#### **AGM Global Vision**

**173 West Main Street**

**PO Box 962**

**Springerville, AZ 85938**

**Tel. 928.333.4300**

**Fax 480.393.4882**

**[support@agmglobalvision.com](mailto:support@agmglobalvision.com)**

**[www.agmglobalvision.com](http://www.agmglobalvision.com)**

# 5 SPECIFICATIONS

## 5.1 SPECIFICATIONS

TABLE 5-1. SYSTEM DATA

ITEM	COBRA TB50-336	COBRA TB50-640	COBRA TB75-336	COBRA TB75-640
Optical Magnification	2.9x	1.7x	4.3x	2.6x
Objective Lens Type	Germanium			
Type of Focal Plane Array	FLIR Tau 2			
Frame Rate	60 Hz	30 Hz	60 Hz	30 Hz
Pixel Array Format	336x256	640x512	336x256	640x512
Pixel Size	17 µm			
Pixel Display Format	800x600			
Display Brightness	Discretely Adjustable to 8 Levels			
Turn-on Time, max	3 sec			
Digital Zoom	2x, 4x	2x, 4x, 8x	2x, 4x	2x, 4x, 8x
Temperature Imaging Modes (Image Palettes)	White Hot, Black Hot, Fusion, Rainbow, Globow, Ironbow1, Ironbow2, Sepia, Color1, Color2, Ice-Fire, Rain, and OEM			
User-adjustable Image Enhancement Tools	<ul style="list-style-type: none"> <li>• Active Contrast Enhancement (ACE) - "CONTRAST"</li> <li>• Second Generation Digital Detail Enhancement (DDE) - "SHARPNESS"</li> <li>• Smart Scene Optimization (SSO) - "SMART SCENE"                             <ul style="list-style-type: none"> <li>• Automatic Gain Control (AGC) - "GAIN"</li> </ul> </li> <li>• User-Controlled Manual Non-Uniformity Correction / Flat-Field Correction (UCMNUC/FFC)                             <ul style="list-style-type: none"> <li>• Silent Shutterless NUC* (SSN)</li> </ul> </li> </ul>			
Analog Video Input/ Output Format (resolution)	PAL (768x574 pixels)* / NTSC (640x480 pixels)			
Interfacing	<ul style="list-style-type: none"> <li>• Micro-USB (Power bank 5V)</li> <li>• Universal S620 connector (Power In, Analog Video In/Out, Wi-Fi Attachment, HD Recorder, Extended Battery Pack)</li> </ul>			

\*Default setting (may be altered at the customer's request).

**TABLE 5-2. OPTICAL DATA**

ITEM	COBRA TB50-336	COBRA TB50-640	COBRA TB75-336	COBRA TB75-640	
Field of View	- ang. X degrees	7.8	14.8	4.3	8.3
	- ang. Y degrees	5.9	11.8	3.2	6.6
Objective Focal Length	50mm		75mm		
Objective F-number	1:1		1:1		
Exit Pupil Diameter	14mm				
Eye Relief	16mm				
Focus Method	Manual				
Focusing Range	5m to inf.				
Diopter Adjustment	Manual				
Diopter Adjustment Range	±5 diopter				

**TABLE 5-3. ELECTRICAL DATA**

ITEM	DATA
Battery	Two CR123A 3V Lithium batteries or CR123 rechargeable batteries with voltage from 3.0V to 3.7V (2)
Current Consumption, max	320 mA
Battery Life at 20°C (68°F)	Up to 4 hr. (optional up to 12 hr.)
Extended Battery Pack	Two 18650 rechargeable batteries (3.7V), four CR123 rechargeable batteries with voltage 3.7V max, or four standard CR123A 3V Lithium batteries (operational time up to 8 hr.)
External Power Supply	6 VDC/ 600mA

**TABLE 5-4. MECHANICAL DATA**

ITEM	COBRA TB50-336 COBRA TB50-640	COBRA TB75-336 COBRA TB75-640
Overall Dimensions	270 × 122 × 65 mm (10.6 × 4.8 × 2.6 in)	305 × 122 × 89 mm (12 × 4.8 × 3.5 in)
Dimensions w/o Eyecups	237 × 106 × 65 mm (9.3 × 4.2 × 2.6 in)	272 × 106 × 89 mm (10.7 × 4.2 × 3.5 in)
Weight (w/o Batteries)	0.8 kg (1.8 lb)	1.28 kg (2.8 lb)

**TABLE 5-5. ENVIRONMENTAL DATA**

ITEM	DATA
Operating Temperature	-40 to +50°C (-40 to +122°F)
Storage Temperature	-50 to +70°C (-58 to +158°F)

# APPENDIX

## A. SPARE PARTS LIST

The parts authorized by this list of spare parts are required for operator maintenance. The list includes parts that must be removed before replacing authorized parts.

The PART NO. column indicates the primary number used by the manufacturer, which controls the design and characteristics of the item in terms of its engineering drawings, specifications, standards, and inspection requirement, to identify an item.

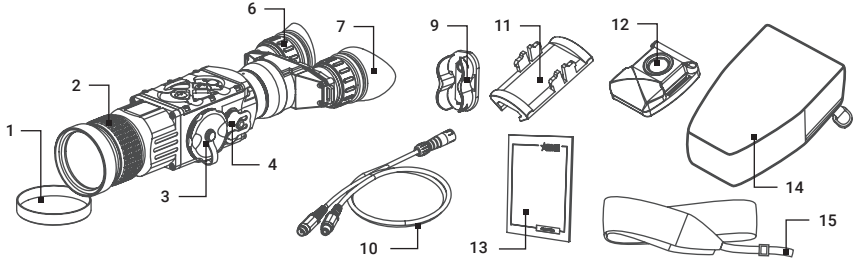

FIGURE A-1. COBRA SPARE PARTS LIST

**TABLE A-1. COBRA SPARE PARTS LIST**

<b>ITEM</b>	<b>DESCRIPTION</b>	<b>PART NO.</b>
1	50mm Objective Lens Cap	GOL500BLCP
-	75mm Objective Lens Cap	GOL750BLCP
2	50mm Objective Lens Assembly	GOL500BLAS
-	75mm Objective Lens Assembly	GOL750BLAS
3	Battery Cap	AGMTIDBCP
4	Connector Cap	AGMTIDCNCP
5	Operation Switch (not shown)	AGMTIDOPSW
6	Eyepiece Assembly	AGMTIBIPAS
7	Eyecup	AGMTIBECP
8	Side Picatinny/Weaver Rail (not shown)	AGMTIDSPR
9	Battery Cassette	AGMTIDBTCS
10	Video Cable	AGMTIDVCB
11	Wireless Remote Control	AGMTIDWRC
12	Picatinny Adapter for Wireless Remote Control	AGMTIDPARC
13	Operation and Maintenance Manual	AGMTIBOMM
14	Carrying Case	AGMTIBCRCS
15	Neck Strap	AGMTIDNCST



Blank page with horizontal dotted lines for writing.



## **AGM Global Vision**

### **MAIN OFFICE**

173 West Main Street

PO Box 962

Springerville, AZ 85938

USA

Tel. +1.928.333.4300

Fax +1.480.393.4882

[info@agmglobalvision.com](mailto:info@agmglobalvision.com)

[www.agmglobalvision.com](http://www.agmglobalvision.com)

### **EUROPEAN OFFICE**

Andrey Lyapchev #7

Sofia, P.C. 1756

Bulgaria

Tel. +44.292.255.0509

[info@agmglobalvision.eu](mailto:info@agmglobalvision.eu)

[www.agmglobalvision.eu](http://www.agmglobalvision.eu)

[AGMglobalvision.com](http://AGMglobalvision.com)